

Installer Guide: Condensate discharge pipe installation

November 2023 Issue 3.0



Condensing Boiler

Industry guidance for installers - endorsed by
HHIC members

In recent years the UK has experienced prolonged spells of sub-zero temperatures down to minus 20 centigrade and below in many areas. This resulted in a significant increase in the number of calls to boiler manufacturers and heating engineers from householders with condensing (high efficiency) boilers where the condensate discharge pipe had frozen and become blocked with ice causing the boiler to shut down. We can make frozen condensate a thing of the past.

In the vast majority of cases such problems occur where the condensate discharge pipe is located externally to the building for some part or all of its length and has not been insulated and sealed correctly.

British Standards, Building Regulations and industry guidance currently advise on how condensate discharge pipes should, be run either internally or externally, or a combination of both. This document gives guidance on how to install the pipes in order to reduce the possibility of freezing.

However, in certain circumstances this guidance may not be sufficient to prevent freezing in extreme conditions with widespread and prolonged sub-zero temperatures.

With the UK weather patterns showing more “extremes” the following guidance updates previously published HHIC guidance on recommendations on condensate discharge pipe installation.

******Boiler Manufacturer’s Warranty Information**

It should be noted that where the manufacturer’s instructions have not been followed then the boiler warranty may not be valid.

Note - It is the responsibility of the heating engineer when installing a new boiler to accurately complete the Benchmark Commissioning checklist (online, via the Benchmark App or manufacturers loyalty platform) confirming that the condensate has been fitted correctly to the latest manufacturers instructions and using the enclosed guidance to ensure protection of the boiler and customer.

Summary of main requirements

Making sure the condensate discharges as fast and as hot as possible to the appropriate termination helps provide maximum protection.

Internal Condensate Pipe Discharge Connection -Where an installer is fitting a new or replacement boiler, the condensate discharge pipe shall be connected to an internal "gravity discharge point" such as;

- **An internal soil stack (preferred method)**
- Internal kitchen or bathroom waste pipe such as washing machine, sink, basin, bath or shower waste terminated internally. (See diagrams for recommended connection points)
- External waste pipes shall be a minimum of 30mm internal diameter, insulated with a minimum of 13mm pipe insulation that is waterproof, UV resistant material, sealed correctly on every joint and through the fabric of the wall terminated below the grid but above the water line to protect from wind chill.
- Fit a suitable drain/leaf guard to prevent wind chill and debris entering the grid.
- Cut the end of the external waste pipe at 45 degrees where it terminates into the grid to help reduce the potential for the pipe to freeze and the insulation shall run to the tip of the pipe.
- Where possible ensure the pipe insulation is sealed through the fabric of the wall and also seal all joints on the insulation to help prevent freezing and wind chill.

Condensate Pumps

Where it is not possible to connect the boiler condensate discharge pipe directly to an internal "gravity discharge point" then the installer shall use a condensate pump connected to a suitable internal soil stack (preferred method), internal kitchen or bathroom waste pipe such as a sink, basin, bath or shower waste.

Existing Installations

When servicing or repairing a boiler the heating engineer shall check how the condensate has been fitted and terminated, especially those that have external drains. This is to see if they can be terminated internally to a soil stack or upgraded to the latest guidance, making sure all external pipework is insulated, sealed and terminated correctly.

Note - The responsible person (home owner) should be advised and it is recommended that the installer completes the responsible persons frozen condensate information leaflet as a suitable means for advising

This guidance should be followed in conjunction with manufacturer's instructions where work is carried out to "upgrade" the condensate discharge system to reduce the risk of freezing in extreme conditions and it is recommended that the condensate pipe is identified with a suitable label or marking, and highlighted to the consumer, even if the responsible person does not go ahead with the upgrade so as to allow easier identification in the future.

Manufacturer's Instructions

The latest manufacturer's instructions shall be followed for the correct connection of the condensate discharge pipe from the boiler as this may vary due to the design of the boiler. For example, a trap is not required in the condensate discharge pipework if there is a trap with a minimum condensate seal of 75 mm incorporated into the boiler.

Internal Condensate Pipe Discharge Termination

Internal condensate discharge pipework shall be a minimum of 19mm ID (typically 22mm OD) plastic pipe or as per manufacturer's instructions and this should "fall" a minimum of 45mm per metre away from the boiler, taking the shortest practicable route to the termination point.

(45mm as per BS6798, 52mm per metre as per industry practice is specified in the following diagrams)

To minimise the risk of freezing during prolonged sub-zero conditions, an internal "gravity discharge point" such as an internal soil stack (preferred method), internal kitchen, utility room or bathroom waste pipe e.g. from a sink, basin, bath or shower shall be adopted, where possible.

Note - Use a suitable permanent connection to the foul waste pipe. Figures 1, 2(a), 2(b) show appropriate connection methods.

Manufacturers Instructions shall be referred to when installing boiler condensate discharge pipes

Figure 1 – Connection of condensate discharge pipe to internal soil and vent stack.
Note – Refer to manufacturer's instructions

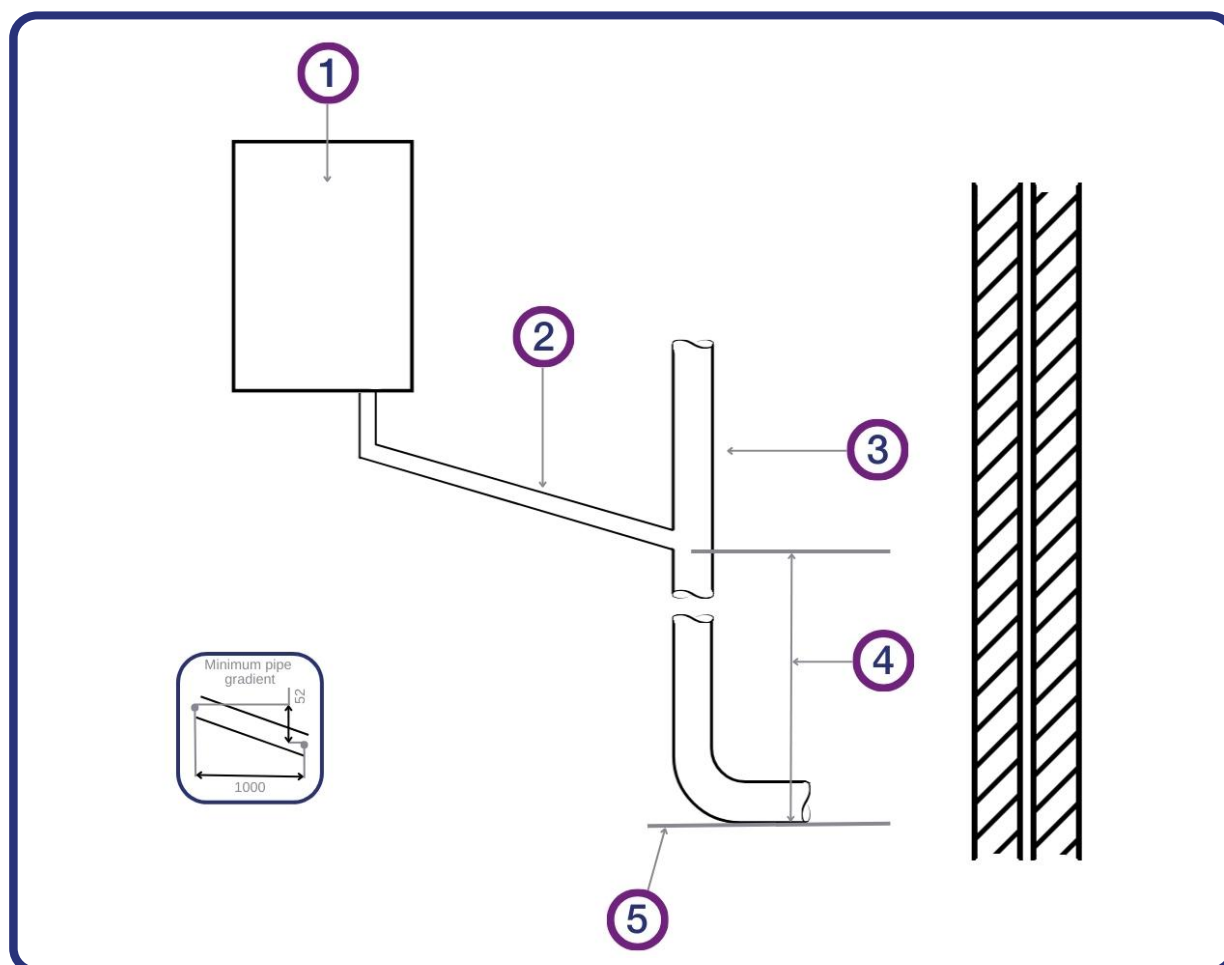

Key

- 1 Boiler
- 2 Minimum internal diameter 19 mm
- 3 Soil and vent stack
- 4 450 mm minimum up to three storeys
- 5 Invert

Internal Condensate Pipe Connection with External Termination

Figure 2(a) – Connection of a condensate discharge pipe downstream of a sink, basin, bath or shower waste trap.

Note – Check manufacturer's instructions to see if an air break or trap is required.

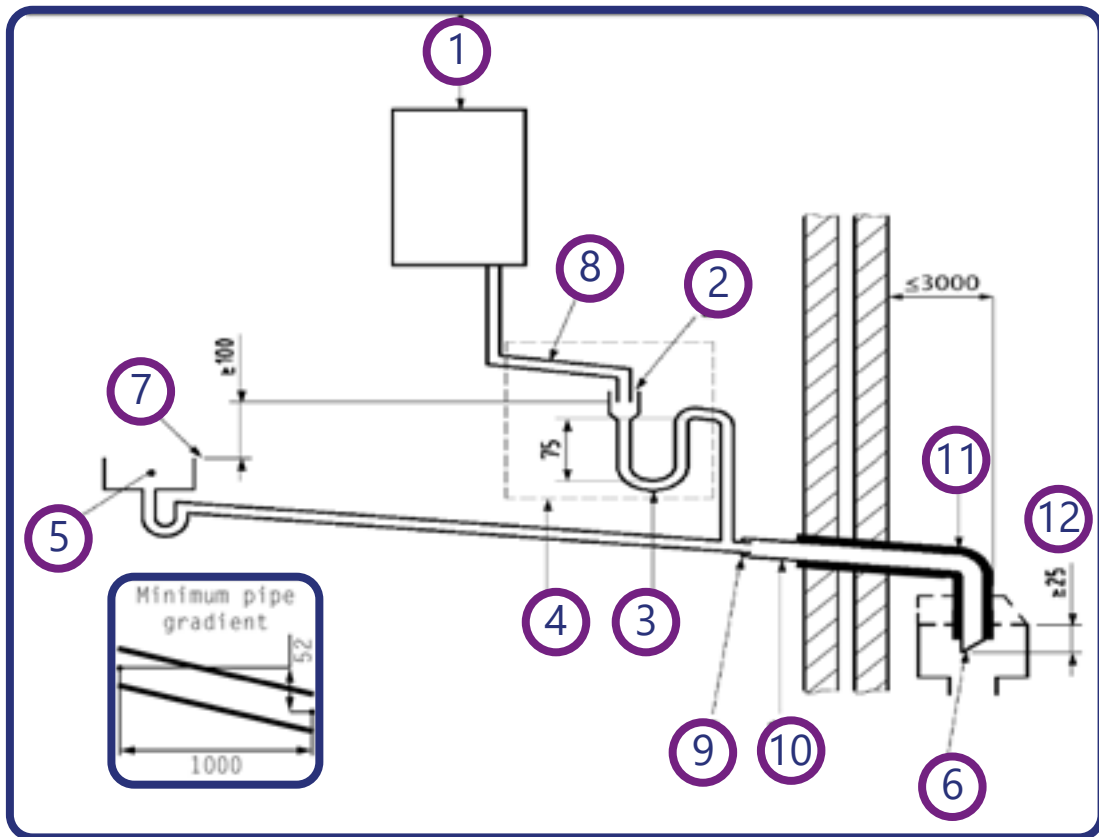

Key

- 1 Boiler
- 2 Visible air break
- 3 75 mm trap
- 4 Visible air break and trap not required if there is a trap with a minimum condensate seal of 75 mm incorporated into the boiler. In this case the 100 mm is measured to the trap in the boiler.
- 5 Sink, basin, bath or shower
- 6 Open end of condensate discharge pipe direct into gully 25 mm min below grating but above water level; end cut at 45 °
Note – the maximum external condensate discharge length is 3 metres
- 7 Sink lip
- 8 Minimum internal diameter 19 mm
- 9 Pipe size transition
- 10 Minimum internal diameter 30 mm taken to the outside
- 11 UV resistant, Water/weather proof insulation
- 12 Drain cover/leaf guard

Manufacturers Instructions shall be referred to when installing boiler condensate discharge pipes

Internal Condensate Pipe Connection with External Termination

Figure 2(b) – Connection of a condensate discharge pipe downstream of a sink, basin, bath or shower waste trap

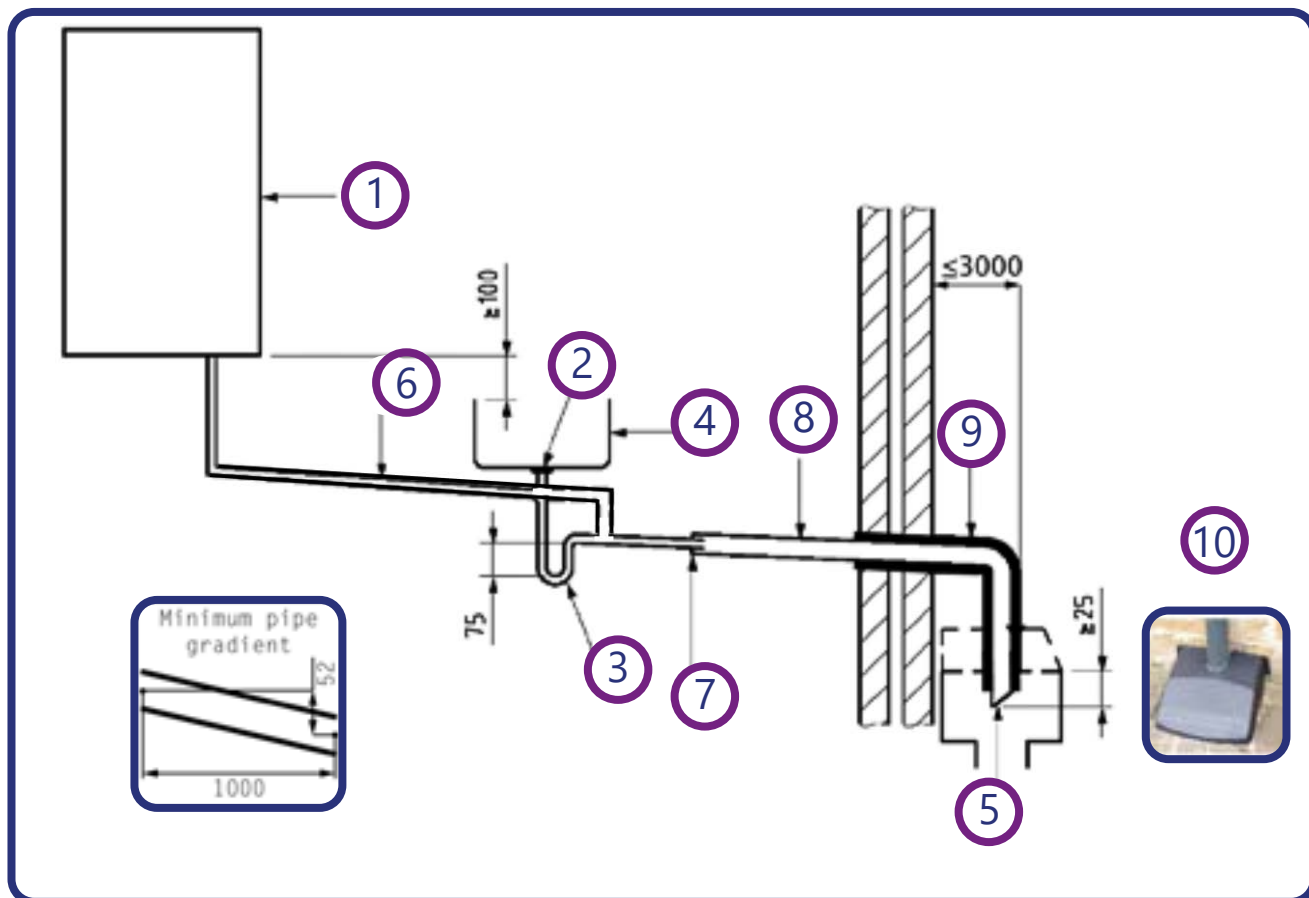

Key

- 1 Boiler
- 2 Visible air break at plug hole –
- 3 75 mm sink, basin, bath or shower waste trap
- 4 Sink, basin, bath or shower with integral overflow
- 5 Open end of condensate discharge pipe direct into gully 25 mm min below grating but above water level; end cut at 45 °

Note – the maximum external condensate discharge length is 3 metres

- 6 Minimum internal diameter 19 mm
- 7 Pipe size transition
- 8 Minimum internal diameter 30 mm taken to the outside
- 9 UV resistant, Water/weather proof insulation
- 10 Fit drain cover/leaf guard

Internal Condensate Pipe Discharge Termination

When connecting to existing pipework it is critical to review the existing installation to ensure the existing pipework is appropriate for condensate discharge having been run correctly and fully insulated and sealed if this is an external or internal termination.

The possibility of waste pipes freezing downstream of the connection point shall be considered when determining a suitable connection point - e.g. a slightly longer pipe run to an internal soil stack may be preferable to a shorter run discharging directly through the wall to an external drain.

Note - Where "gravity discharge" to an internal termination is not physically possible (e.g. the discharge point is above the appliance location, or access is obstructed by a doorway), or where very long internal pipe runs would be required to reach a suitable discharge point, then a condensate pump shall be used.

External waste pipework shall be:

- Only used to take the condensate waste away and no other waste must be connected to keep the pipework free from restrictions or blockages
- Insulated with waterproof UV resistant material.
- All joints sealed correctly stopping water getting between the insulation and waste pipe
- Terminated below the grid but above the water line and a drain/leaf guard fitted.
- Cut at 45 degrees where it terminates into the grid and insulated to the tip of the pipe.
- A minimum thickness of 13mm insulation is recommended for minimum 32mm OD solvent pipe work and fittings
- Where the insulation passes through the wall with a flexible seal for expansion and contraction is required, to stop any moisture getting between the insulation and waste pipe. This also stops any moisture penetrating through the wall, providing a seal supporting energy efficiency



Condensate Pump

Use of a Condensate Pump to an Internal Termination

Condensate can be removed using a proprietary condensate pump, of a specification recommended by the boiler or pump manufacturer. In order to minimise the risk of freezing during prolonged sub-zero spells, the preferred method is internal to the property for terminating the boiler condensate pump to a foul water discharge point should be adopted such as an internal soil stack (preferred method) All waste pipework must be as vertical as possible to take condensate water as fast and as hot as possible to the internal soil stack. Any waste pipework being fitted in an unheated area must be enlarged to 32mm OD, insulated and sealed correctly (solvent weld pipe and fitting). UV is not required as fitted internally

Manufacturers Instructions shall be referred to when installing boiler condensate discharge pipes

External Connections

Only fit a correctly insulated external boiler condensate drain connection if an internal gravity or pumped connection is **impractical** to install.

The pipe work from the boiler shall be of a minimum 19mm ID or if in an unheated area increased to 30mm ID (typically 32mm OD) solvent weld of as per manufacturer's instructions and the condensate discharge pipe shall be run in a standard drainpipe material, e.g. poly (vinyl chloride) (PVC), un-plasticized poly (vinyl chloride) (PVC-U), acrylonitrile butadiene-styrene (ABS), polypropylene (PP) or chlorinated poly (vinyl chloride) (PVC-C).

Note - Fixing centres for brackets should be a maximum of 300mm for flexible pipe and 500mm for solid pipe and manufacturer's recommendations should be followed.

The condensate pipe should be run internally as far as possible before going externally and the pipe diameter shall be increased to a minimum of 30mm ID (typically 32mm OD) if not already, if in an unheated, area before it passes through the wall. The angle of the pipe shall slope downwards by at least 3 degrees as it passes through the wall to assist in maintaining a good velocity as the condensate exits the building.

The external pipe run shall be kept as short as possible to a maximum of 3 metres, taking the most direct and "most vertical" route to the discharge point, with no horizontal sections in which condensate might collect. The external condensate and pipework inside the cavity wall must be insulated to manufacturers instructions

Manufacturers Instructions shall be referred to when installing boiler condensate discharge pipes

External Connections

Figure 3 – Connection of condensate discharge pipe to external soil and vent stack

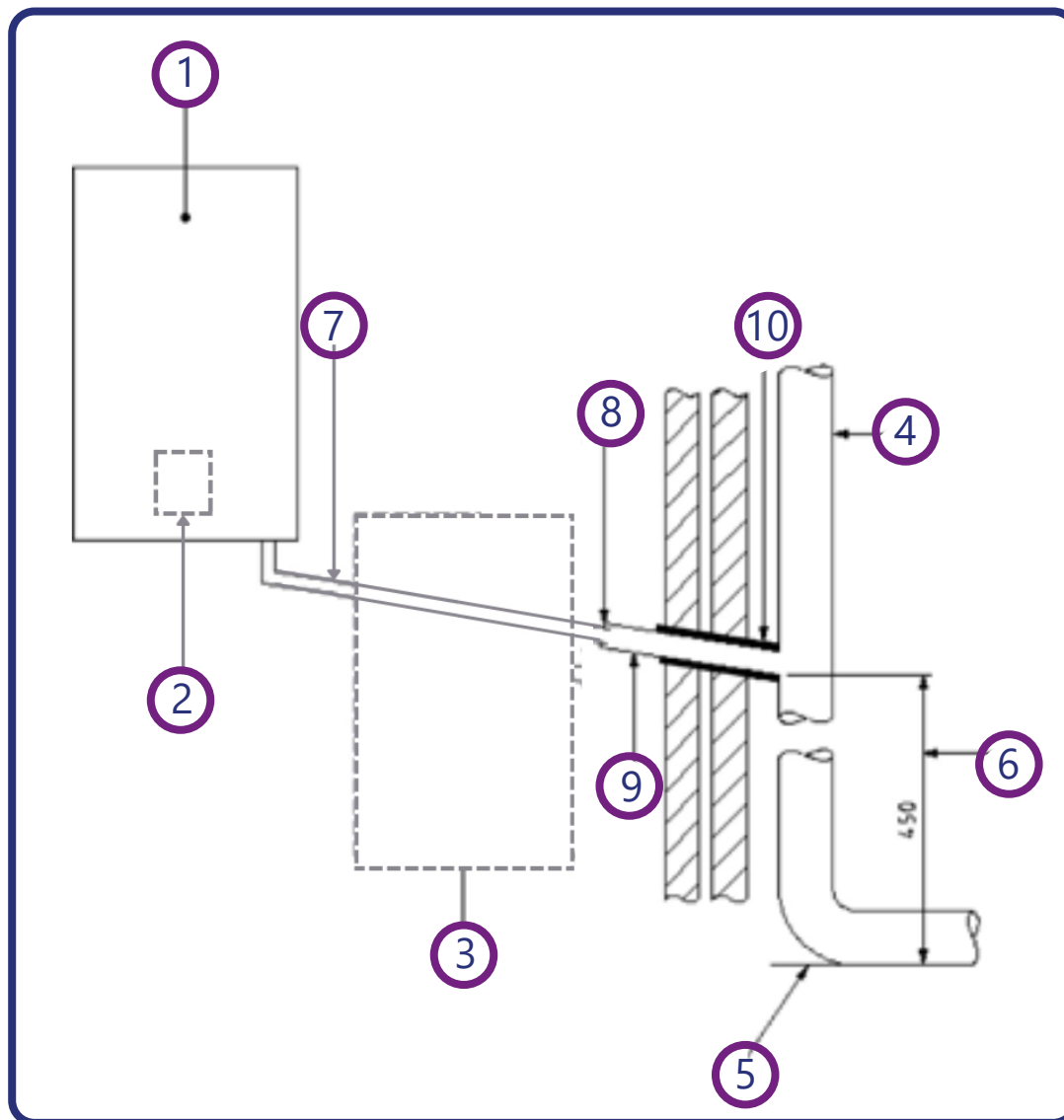

Key

- 1 Boiler
- 2 Internal Trap
- 3 Visible air break and trap not required if there is a trap with a minimum condensate seal of 75mm incorporated into the boiler.
- 4 Soil and vent stack
- 5 Invert
- 6 450mm minimum up to three storeys
- 7 Minimum internal diameter 19 mm
- 8 Pipe size transition point
- 9 Minimum internal diameter 30mm taken to the outside
- 10 UV Resistant, Water/weather proof insulation

Connecting to a rain water downpipe/External Soil Stack

When a rain water downpipe is used as the termination (NB only permissible if this downpipe passes to a combined foul and rainwater drainage system) an external air break shall be installed between the condensate discharge pipe and the downpipe to avoid reverse flow of rainwater into the boiler should the downpipe itself become blocked, flooded or frozen.

Figure 4 shows a suitable connection method. Pipe insulation should be fitted.

External Termination of the Condensate Pipe

Where the condensate discharge pipe is terminated over an open foul drain or gully, the pipe should terminate below the grating level, but above water level, in order to minimise “wind chill” at the open end. Pipe drainage and resistance to freezing will be improved if the termination end of the condensate pipe is cut at 45 degrees as opposed to a straight cut, and insulated to the tip of the pipe.

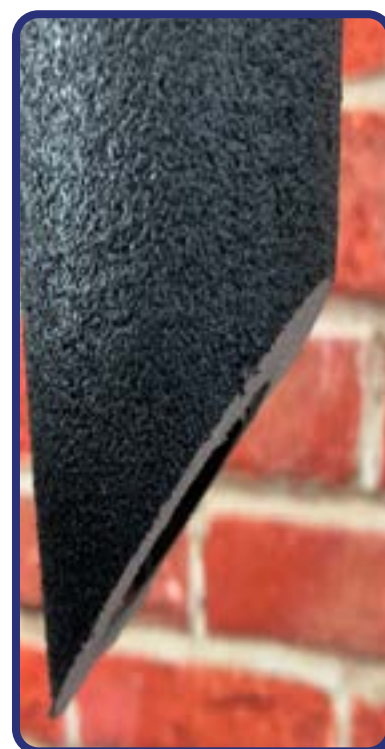

The use of a drain cover (such as those used to prevent blockage by leaves) shall be fitted to offer further protection from wind chill. Figure 4 (following page) shows a suitable connection method. Where the condensate drain pipe terminates in a purpose-designed soakaway any above-ground section of condensate discharge pipe should be run and insulated as described above. Figure 6 (following page)

Manufacturers Instructions shall be referred to when installing boiler condensate discharge pipes

External Connections

Figure 4 – External termination to rainwater downpipe (NB only combined foul/rainwater drain)

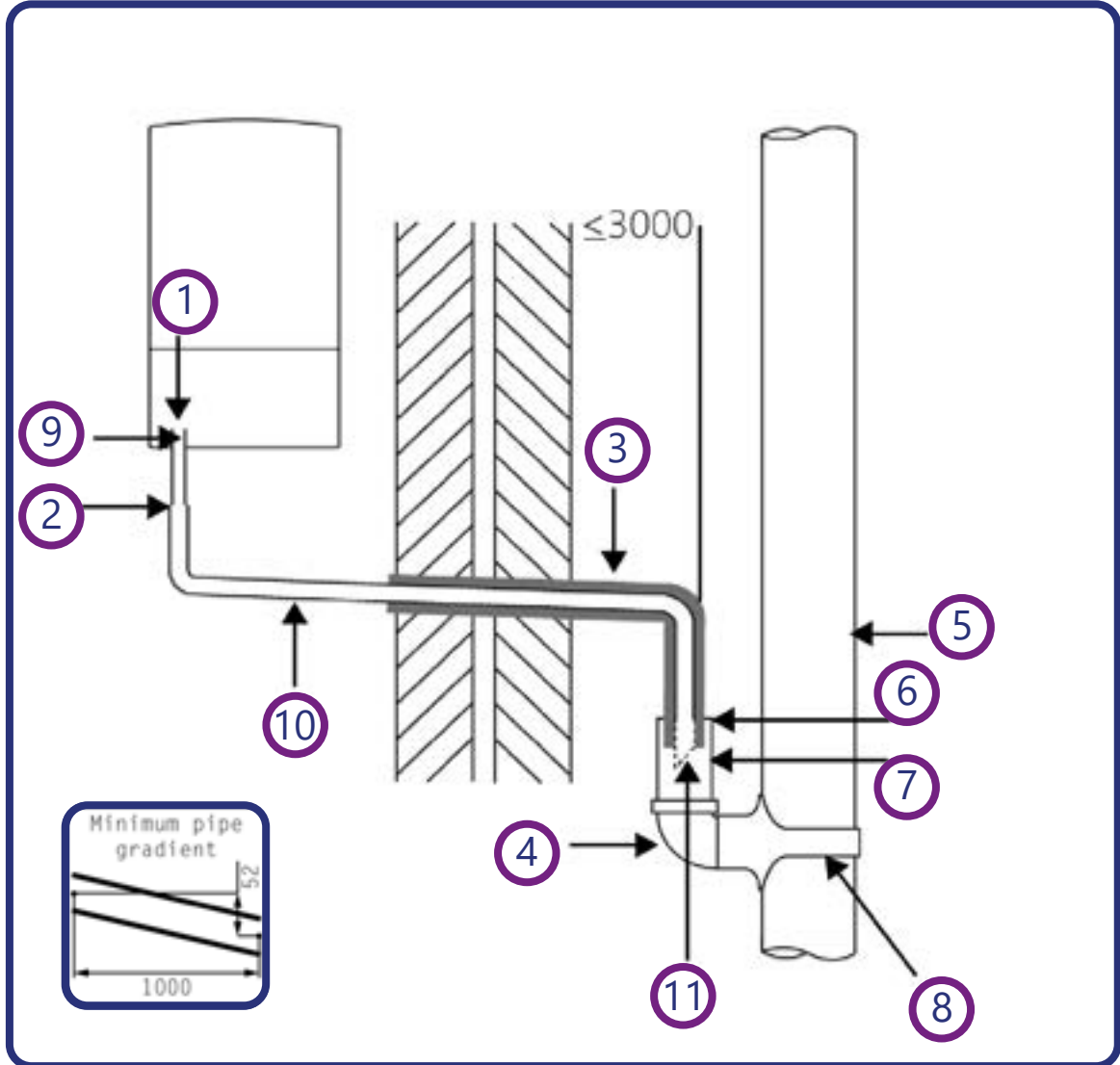

Key

- 1 Condensate discharge pipe from boiler
- 2 Pipe size transition point
- 3 Water/weather proof, UV resistant insulation
- 4 43mm 90° male/female bend
- 5 External rain water pipe into foul water
- 6 External air break
- 7 Air gap
- 8 68mm PVCu strap on fitting
- 9 Minimum internal diameter 19mm
- 10 Minimum external diameter 30mm and through the wall
- 11 End cut at 45°



External Connections

Figure 5 – Preferred Method: External drain, gully or rainwater hopper

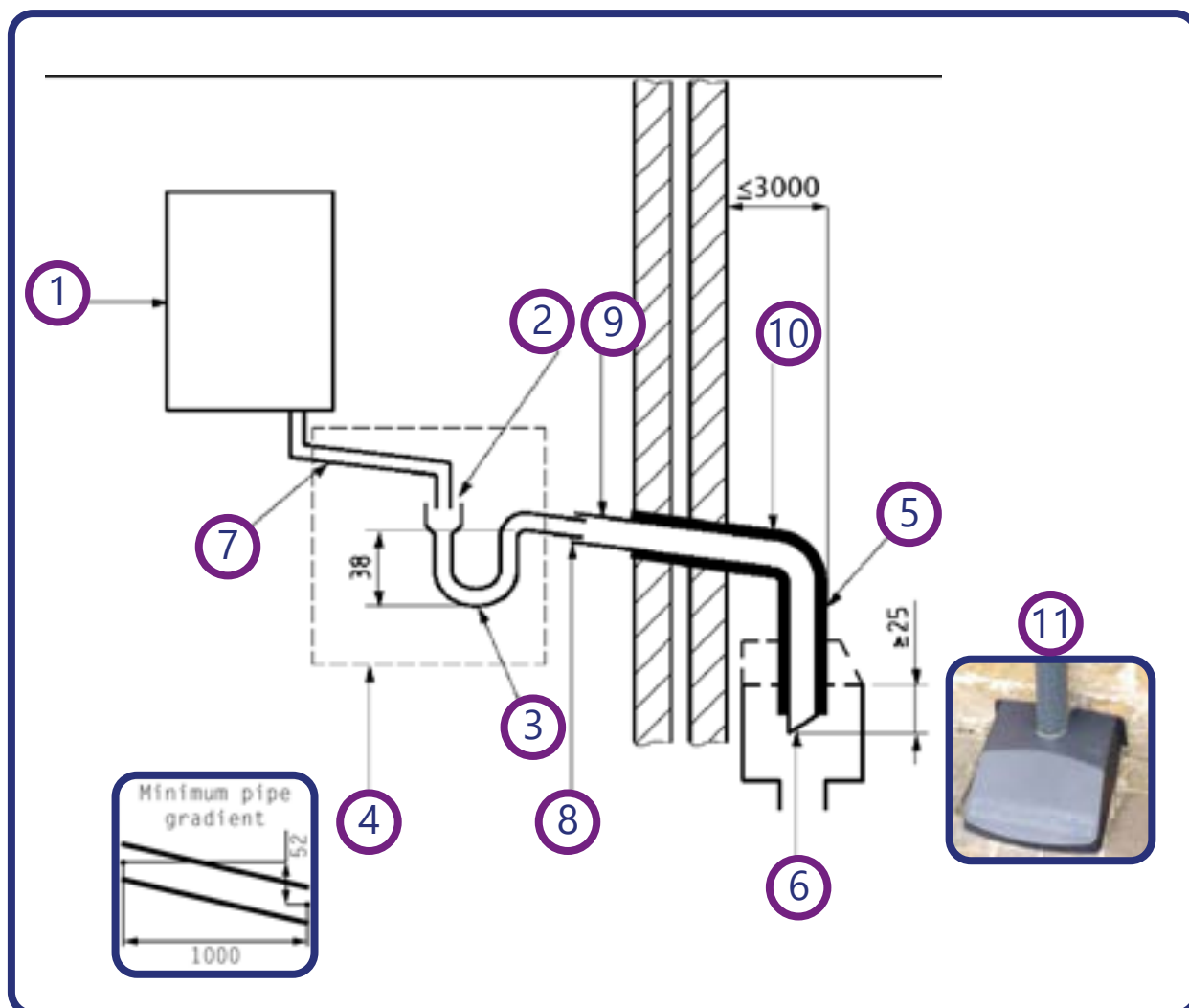

Key

- 1 Boiler
- 2 Visible air break
- 3 38mm minimum trap
- 4 Visible air break and trap not required if there is a trap with a minimum condensate seal of 38 mm incorporated into the boiler – refer to manufacturer's instructions
- 5 External length of pipe 3 m maximum
- 6 Open end of condensate discharge pipe direct into gully 25 mm min below grating but above water level; end cut at 45 °
- 7 Minimum internal diameter 19mm increased to a min of 30mm ID (typically 32mm OD) in an unheated area
- 8 Pipe size transition point
- 9 Minimum internal diameter 30mm to the outside
- 10 Water/weather proof and UV resistant insulation
- 11 Fit drain cover/leaf guard

Manufacturers Instructions shall be referred to when installing boiler condensate discharge pipes

External Connections

Figure 6 – Example of a purpose made soakaway

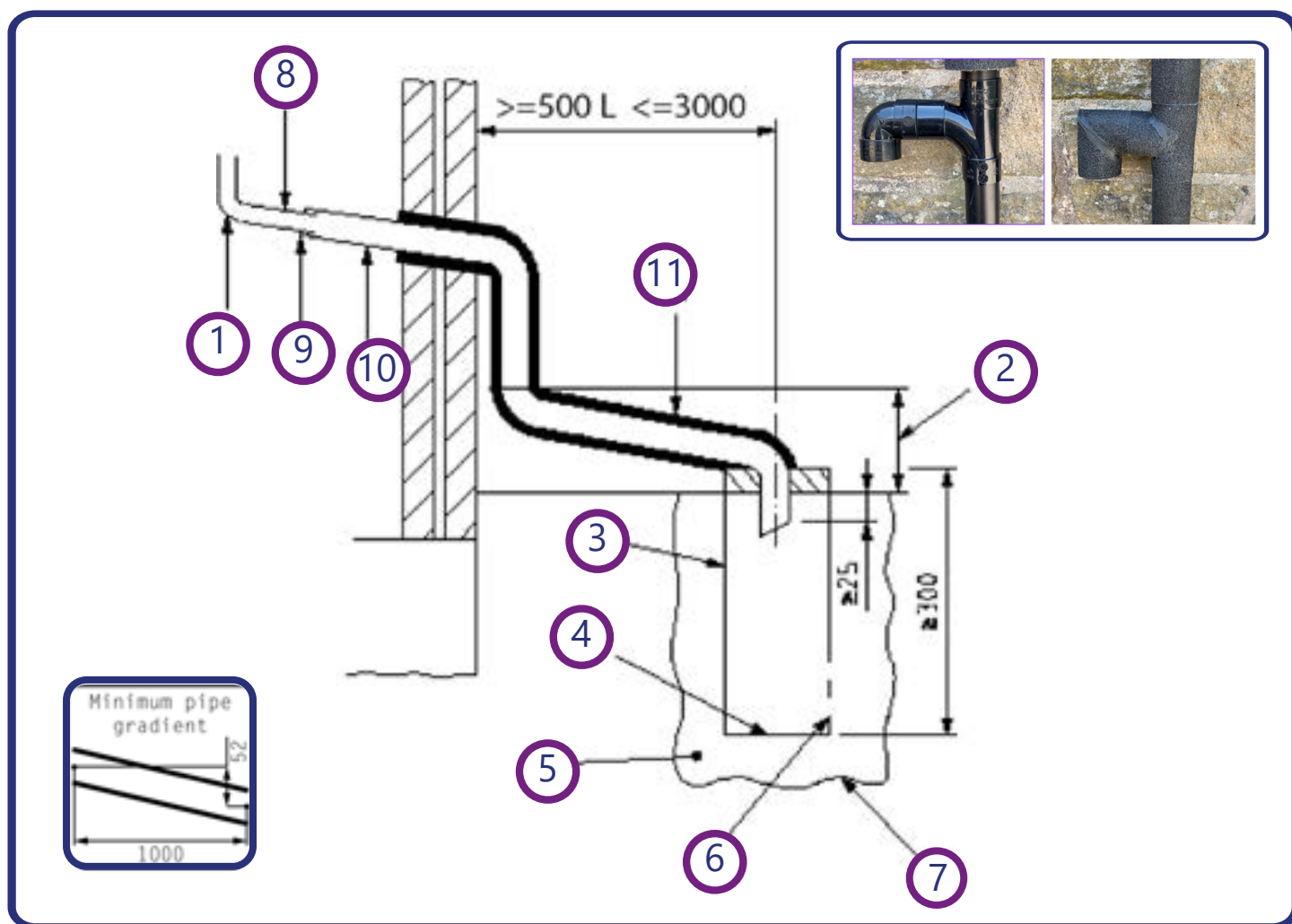

Key

- 1 Condensate discharge pipe from boiler
- 2 Ground (this section of the condensate discharge pipe may be run either above or below ground level); End cut at 45°
- 3 Diameter 100 mm minimum plastic tube
- 4 Bottom of tube sealed
- 5 Limestone chippings
- 6 Two rows of three 12 mm holes at 25 mm centres, 50 mm from bottom of tube and facing away from house
- 7 Hole depth 400 mm minimum by 300 mm diameter
- 8 Minimum internal diameter 19 mm
- 9 Pipe size transition point
- 10 Minimum external diameter 30 mm
- 11 Water/weather proof and UV resistant insulation

Other considerations

Unheated Areas in Buildings

Internal condensate drainage pipes run in unheated areas such as lofts, basements and garages shall be treated as external connections and insulated accordingly. Weather proof materials may not be necessary but where separate sections of insulation join together, including elbow joints then these should be connected, insulated and sealed correctly to prevent them coming apart with a suitable material to help prevent freezing.

Insulation Materials

Insulation used for external condensate pipes, shall have an outer coating that is weather proof, and UV resistant. Use a minimum of 13mm thick insulation for 32mm external pipes. Ensure all pipework is insulated and sealed correctly

Use of Air Breaks In Condensate Discharge Pipes

Heating engineers should follow manufacturer's instructions on the use of air breaks in condensate discharge pipes. An air break is normally required for both rainwater and soak away connections. Refer to manufacturer's instructions for further details on for air break requirements.

Soakaway

If a soakaway is the only alternative to discharge the condensate an external insulated and sealed air break is required. This will allow water to be discharged from the condensate pipe should the soakaway become saturated, and will allow the boiler to continue to operate. Note: If water is discharged from this 'overflow', then increasing the volume of the soakaway pit should be considered.



Manufacturers Instructions shall be referred to when installing boiler condensate discharge pipes

Alternative Solutions

Cold weather protection

Cold weather protection methods approved or endorsed by boiler manufacturers and/or service organisations may be adopted if these are considered suitable by the parties involved. It is the responsibility of the manufacturer of these products to ensure they have completed the necessary testing or calculations to ensure the product offers suitable protection to prevent the condensate pipe from freezing. The product manufacturer should provide information as to what level of external temperature and for what time period the product can protect against sub-zero temperatures, i.e. -15°C for 48 hours.

Electric Trace Heating

Trace heating with an external thermostat can be fitted to the external condensate pipe to raise the temperature of the condensate pipe in freezing conditions. Trace heating takes the form of an electrical heating element run in physical contact along the length of the condensate pipe. The pipe still needs to be insulated and sealed correctly to retain heat losses from the pipe. Heat generated by the element then maintains the temperature of the pipe. If such a system is used then the installation instructions of the trace heating manufacturer and any specific recommendations regarding pipe diameter, insulation, etc. should be followed. All other relevant guidance on condensate discharge pipe installation should also be followed.

Auxiliary Syphon – Fitted Internally

Auxiliary siphons fitted inside the premises assist with the siting of the boiler where an external condensate pipe must be fitted. The storage capacity of the auxiliary siphon increases the volume of condensate discharge reducing the risk of freezing. A further reduction in the potential for the pipe to freeze is achieved when combined with the external insulation requirements and sealing correctly. The aim is to keep the condensate discharge running as fast and as hot as possible, this heats the waste pipe and prevents freezing.

Annex A

Note – Annex A details remedial actions for householders which can be taken if a condensate discharge pipe freezes. This may result in requests for alteration to condensate discharge pipework, in which case the guidance above should be followed.

Frozen Condensate Information Leaflet –Our customer information guide on frozen boiler condensate discharge is also available for download. It includes a condensate assessment form, for engineers to complete and advice to customers during extreme cold weather conditions. www.hhic.org.uk/resources.

Dear Householder,

Your heating engineer has noted that your boiler condensate discharge pipe may be at risk of freezing in prolonged, and extreme cold weather conditions. In recent years we have seen temperatures as low as -20*c in some parts of the UK.

The concern is that your pipe runs externally or in an unheated space for at least some of its length and is liable to freeze in these extreme temperatures as it is not installed in line with the latest guidance, to help guard against freezing. If your pipe freezes, it will cause your boiler to go into “shut off” at a time when you need your heating and hot water the most.

Your heating engineer will advise you on the solutions available to reduce the risk of your pipe freezing, including running the discharge pipe to an internal drainage point (the preferred method if you have an internal soil stack), or installing one of the available products designed to give you added protection against freezing conditions. They will also clearly identify the external condensate discharge pipe for your future reference and may apply an identification label or tape.

Manufacturers Instructions shall be referred to when installing boiler condensate discharge pipes

Annex A

Your Engineer has identified the potential for your boiler to freeze in extreme conditions as the following:

Risk category	Explanation	Engineer selection
RED	High risk of freezing- TAKE ACTION	<input type="checkbox"/>
AMBER	Medium risk of freezing- Strongly advise action to be taken	<input type="checkbox"/>
GREEN	Low risk but some improvement required	<input type="checkbox"/>

Work required:

Name: _____

Company: _____

Telephone: _____

Email: _____

Thawing Frozen Condensate Pipes

Below is an explanation of what you would need to do to resolve the problem in the event that the pipe was to freeze. We would highly recommend getting a professional to assess the situation and resolve the problem by upgrading the condensate. If you do try to unfreeze your condensate, please take care as there are risks due to the related weather conditions.

1. Locate the blockage

The Condensate discharge pipe usually freezes at the most exposed points outside, such as the open end of the pipe, at a bend or elbow, or where there is a dip in the pipe where condensate can collect. (If the condensate has no insulation there may be an extensive frozen area)

2. Thaw the Frozen Pipe

The Condensate can be thawed in a number of ways. By applying a hot water bottle, a microwaveable heat packs around the blockage or by pouring warm water onto the pipe. Do not use boiling water. Do not use water if your condensate discharge pipe is not easily reached from ground level, Do not put yourself at any undue risk. Seek assistance and engage a professional heating engineer. Be aware that if you are pouring water onto the pipe this can also quickly freeze on the ground, causing a slip hazard.

3. Reset/ Restart the boiler

Once the frozen blockage has been cleared, the boiler will usually need to be reset, and advice on how to do this can be found in the user instructions manual for your boiler. Normally this will involve simply pressing a reset button on the front of the boiler, or in some cases by isolating the electrical supply to the boiler and switching it back on

 info@hhic.org.uk

 01926 513777

 @HHIC

Camden House
Warwick Road
Kenilworth
CV8 1TH

