

# Consumer Guide: Protecting your boiler & heating system

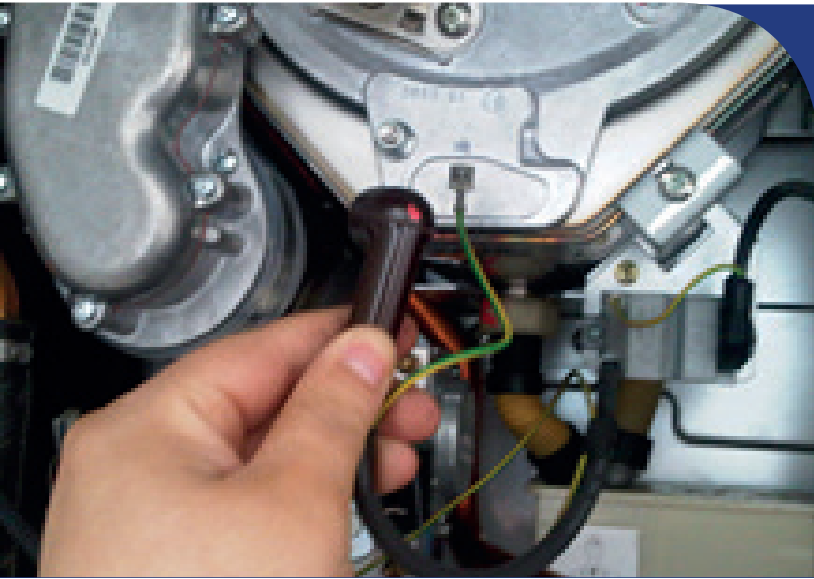

**Investing in a new, highly-efficient condensing boiler is a wise move – but few home-owners are aware of the important role water treatment plays in ensuring your new boiler performs as expected – and continues to do so.**



### Correct installation

Boiler manufacturers offer generous product warranties on new appliances, but this is conditional on the heating system being effectively cleaned at the time of installation, to ensure that system debris, sludge and corrosion cannot block or restrict the boiler waterways and its functional hydraulic parts. Ensure your installer completes the Benchmark commissioning documentation to confirm that this has been done.

### Guarding against boiler breakdown

Cleaning the system, via a gravity or mains flush, or a Powerflush, can restore the system to its original condition, before an inhibitor is added to offer ongoing protection and help prevent any further corrosion occurring in the future. A clean, protected system ensures your boiler can heat your radiators and hot water, quietly and efficiently. You have the peace of mind which comes from knowing that, should the unexpected occur, your warranty is protected.

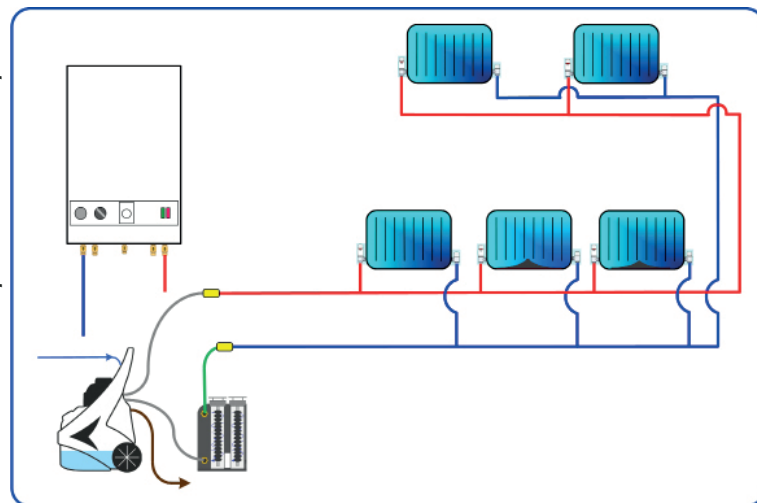

### Powerflushing

A Powerflush is an effective means of removing corrosion and sludge from heating systems, using a specialised machine to circulate chemicals around your system, before flushing the old system water away and down the drain. This results in a thorough cleanse and is particularly well-suited to heavily sludged systems. Don't worry! – despite the name, the pressure generated by the machine is similar to normal pressures experienced in a heating system (sealed), meaning the Powerflush will not damage your boiler, radiators or pipework. It is actually the way the machine works – generating high flow-rates, as well as the ability to reverse the direction of flow, which makes it so effective. Devices employing additional external sludge collection and removal, e.g. through magnetic filtration, can greatly improve the speed and effectiveness of all recognised methods for cleaning heating systems, including Powerflushing.

## Do I need a system filter?

It is a good idea to invest in a system filter, as this is installed in the return to your boiler, ensuring any residual deposits present in the system are collected and kept from entering the boiler. Different designs exist but can collect magnetic and non-magnetic particles, and are designed to be easily cleaned out by service engineers (typically at the time of your annual boiler service).

## What about limescale?

Limescale is particularly problematic in hard water areas, and for combi boilers, which frequently take in new, "fresh" water and heat it directly. Part L of The Building Regulations recommends that in hard water areas the cold mains supply to combi boilers is treated with a scale prevention device. This ensures that lime-scale does not block the heat exchanger in your combi boiler, reducing flow rates and the temperature of the hot-water delivered.

## Water softeners

Water softeners are a way to offer "whole house" protection against limescale. Some boilers are not recommended for use with softened water (ion-exchange) in the primary circuit, so, if in doubt, always fill the heating system using un-softened mains water. This can be done by simply opening the bypass valve on the water softener installation plumbing temporarily whilst filling, or by having a separate mains water feed directly to the heating system filling loop, or feed and expansion tank. The boiler manufacturer may give more detailed advice in their appliance instructions, which **must always be complied with to ensure that your boiler warranty is protected.**

## What happens now?

You can sit back and enjoy the warmth and comfort provided by your new boiler. Don't forget, if the system is ever partially drained (e.g. radiators removed for decorating), the same inhibitor used at the time of installation should be added to the system to maintain protection. It is also recommended that inhibitor levels are checked at regular intervals, most conveniently by your heating engineer at the time of annual servicing.



It is recommended that the boiler and system are serviced and checked annually, to ensure that they are running in tip-top condition.

The Heating and Hotwater Industry Council, **HHIC**, is a not for profit trade association committed to effectively driving, supporting and promoting the sustained growth of the UK domestic heating and hot water industry.

This document was drafted under the guidance of the HHIC water treatment group, whose members are;

- **Kamco**
- **Adey**
- **Sentinel**
- **BEAMA Water Treatment**
- **Lettergold**
- **Harvey Water Softeners**
- **Monarch Water**
- **Endotherm Enterprises**

When you're looking for a gas engineer, checking if they're on the **Gas Safe Register** is the surest route to safety for you and your family. It's the only list of engineers qualified to work legally on gas appliances.

Locate your nearest **Gas Safe** registered engineer at;  
**[www.gassaferegister.co.uk](http://www.gassaferegister.co.uk)** or call **0800 408 5500**



Your local Gas safe registered business is;

Our Gas safe registration number is;

To book an appointment contact:



[info@hhic.org.uk](mailto:info@hhic.org.uk)



01926 513777



@hhic

Camden House  
Warwick Road  
Kenilworth  
CV8 1TH

**HHIC**  
HEATING & HOTWATER  
INDUSTRY COUNCIL